

Capillary Clip



Features & Benefits

The CAPILLARY CLIP HAS EVOLVED!

Sturdy nylon design replaces old copper "one size only" clips.

New capillary clip design enhancements:

- Unit has the ability to hold 3 different sizes of capillary tubing 1/8", 1/4" and 3/8"
- Slots are available to use nylon zip ties to hold tubing in place
- Inside tapered ridges allow tubing to be snapped in then held into place.
- 90 degree top mounting ability
- Reinforcement between 90 deg mounting and clip has the ability to hold a single sensor (sliding it in from the end) of approx 1/4" diameter
- Scribe or score mark allows units to be separated into 2 parts. One part can be used as a capillary mounting clip for mounting in the same plane. The other part can be used as a sensor mounting bracket for 1/4" diameter sensors. Either part can be discarded if not used.
- Available in 3 colors: NATURAL, BEIGE & GREY

Dimensions

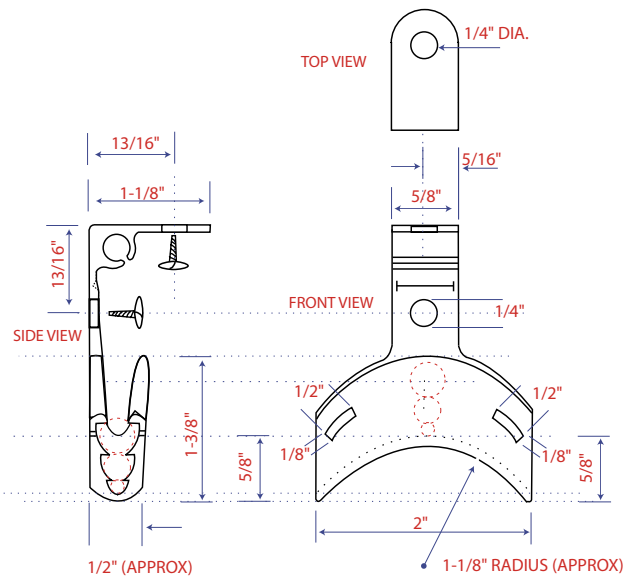

Design Enhancements

Reinforcement between 90 deg mounting and clip has the ability to hold a single sensor (sliding it in from the end) of approx 1/4" diameter

OPENING TO FIT 1/4" TUBE or SENSOR

90° TOP MOUNTING CAPABILITY

Scribe or score mark allows units to be separated into 2 parts. One part can be used as a capillary mounting clip for mounting in the same plane. The other part can be used as a sensor mounting bracket for 1/4" diameter sensors. Either part can be discarded if not used.

OPENINGS TO HOLD CAPILLARY TUBES OF THREE SIZES:

3/8"

1/4"

1/8"

SLOTS ARE AVAILABLE TO USE NYLON ZIP TIES TO HOLD TUBING IN PLACE IF NEEDED.
NOTE: THIS MIGHT NOT BE NECESSARY AS INSIDE TAPERED RIDGES ALLOW TUBING TO BE SNAPPED IN AND THEN HELD IN PLACE

Ordering Info

CC1-N NATURAL
CC1-B BEIGE
CC1-G GREY

Custom colors available (10,000 piece minimum)